

FAST LINE BALL VALVE KIT NCNA-S

D.H.W. PRODUCTION WITH 2 HEAT SOURCES

1/2" - 3/4" - 1"

12" x 90°

INSTRUCTION SHEET

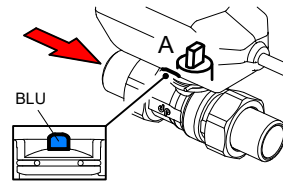
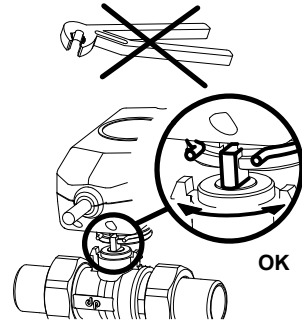
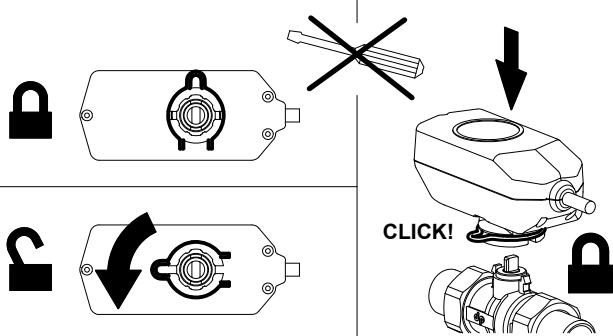

2 WAYS

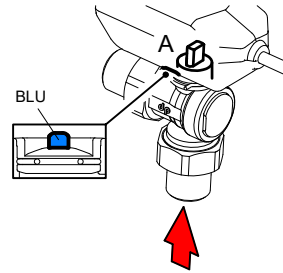
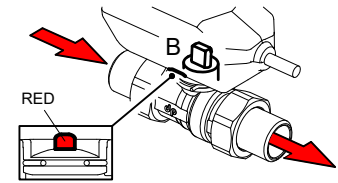

2 WAYS SQUARE

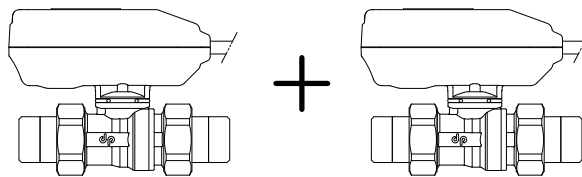
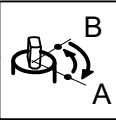
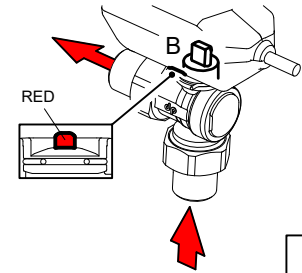

R2A
NORMALLY
CLOSED

R2AA
NORMALLY
OPEN

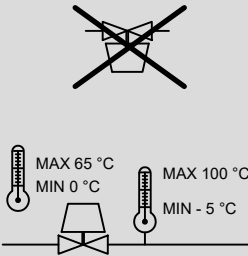
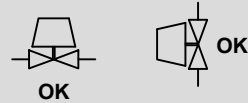

ACTUATORS FEATURES		
	R2A	R2AA
POSITION WITH CLOSE COMMAND	CLOSED	OPENED
TYPE OF COMMAND	2 WIRES	
SUPPLY	230 V - 50 Hz	
ELECTRIC CONSUMPTION	4 W	
WORKING TIME	12 " x 90 °	
WORKING ENVIRONMENT TEMPERATURE	0 ÷ 65 ° C	
IP RATING	IP 54	
CONTROL CABLE	4 x 0.75 mm ² - 1 meter	

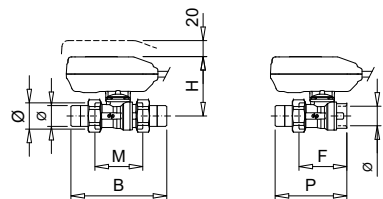

Ø	Ø	H	M	B	F	P
1/2"	3/4"	75	59	113	59	86
3/4"	1"		60	120	60	90
1"	1" 1/4"	78	72	141	72	107

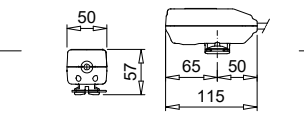
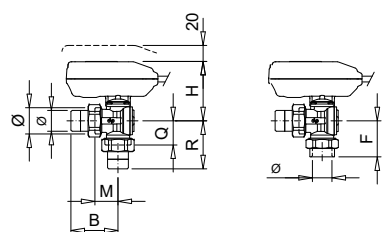

Ø	Ø	H	M	B	Q	R	F
1/2"	3/4"	75	28	55	29	50	43
3/4"	1"		29	59	30	60	45
1"	1" 1/4"	78	34	69	35	70	52

BEFORE INSTALLATION, MAKE SURE THE HYDRAULIC CIRCUIT IS CLEANED OF SOLID BODIES SUCH AS WELDING OR THREADING RESIDUES

FEATURES VALVE BODY	
FLUID COMPATIBLE	WATER OR LIQUIDS COMPATIBLE WITH PTFE AND EPDM
TEMPERATURE LIMITS OF THE FLUID	- 5 ÷ 100 ° C
MAXIMUM WORKING PRESSURE	10 bar
MAXIMUM DIFFERENTIAL PRESSURE	4 bar

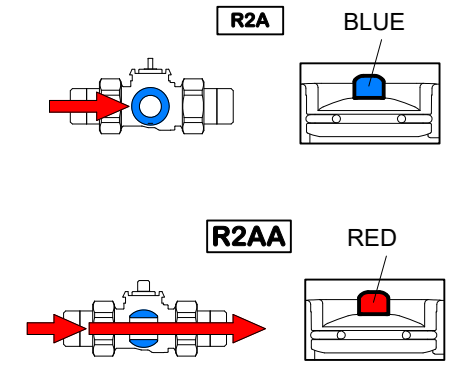
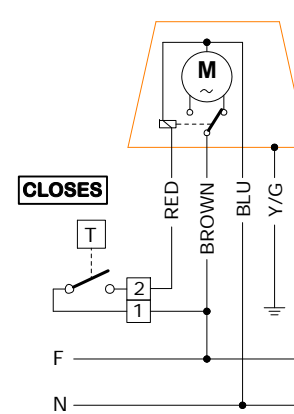

D.H.W. WITH 2 GENERATORS AND "FDG" DE PALA CONTROL UNIT

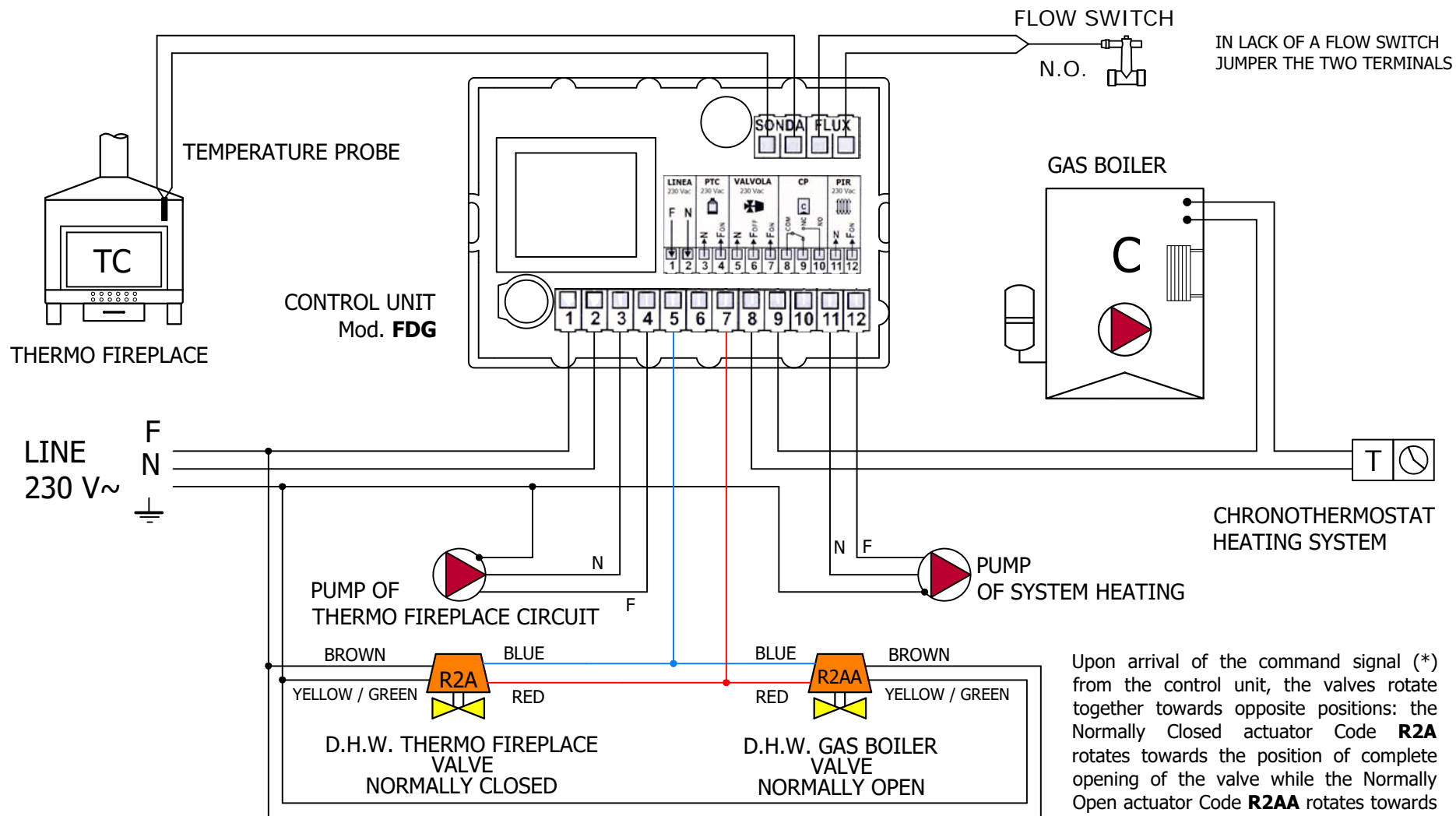

Upon arrival of the command signal (*) from the control unit, the valves rotate together towards opposite positions: the Normally Closed actuator Code **R2A** rotates towards the position of complete opening of the valve while the Normally Open actuator Code **R2AA** rotates towards the complete closure of the valve.

* The command signal of the control unit is factory set at 40°C. It is possible set the temperature by acting on the control unit setting. Refer to the related instruction sheet.

D.H.W. WITH 2 GENERATORS AND IMMERSION THERMOSTAT

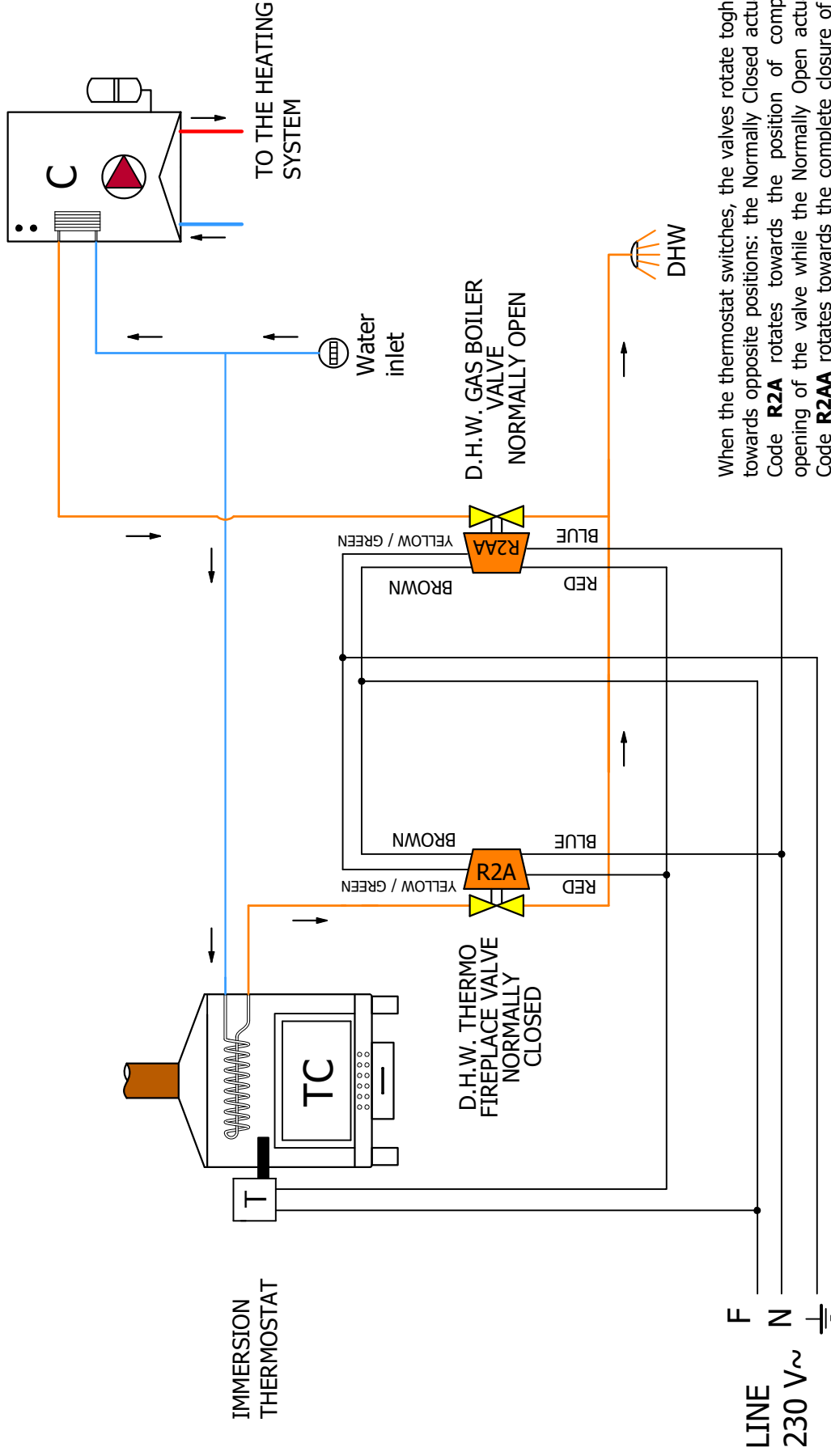

When the thermostat switches, the valves rotate together towards opposite positions: the Normally Closed actuator Code **R2A** rotates towards the position of complete opening of the valve while the Normally Open actuator Code **R2AA** rotates towards the complete closure of the valve.

The contents of this instruction sheet are intended for the company that takes care of installation and maintenance. The hydraulic and electrical installation operations must be carried out by qualified personnel, in compliance with the laws and regulations of each country where the product is intended. The NCNA-S Kit must be provided only in the application context for which it was designed. The company De Pala srl, in the continuous process of improving its products, reserves the right to make any technical, dimensional and aesthetic changes it deems necessary without prior notice.

de pala

33080 ROVEREDO IN PIANO (Pordenone) - Via del Lavoro, 10 - ITALY
 Telefono 0434.920466 0434.923166 FAX 0434.591473

Web : www.depala.it
 e-mail : info@depala.it